

RECOMMENDED P.C.B. LAYOUT

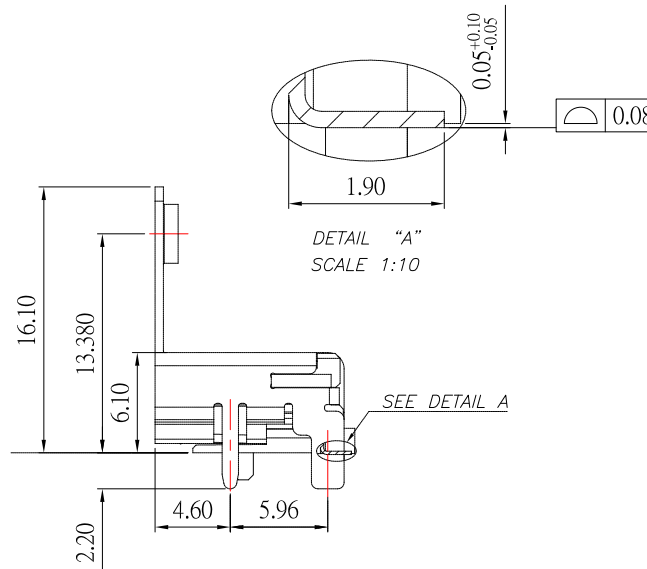
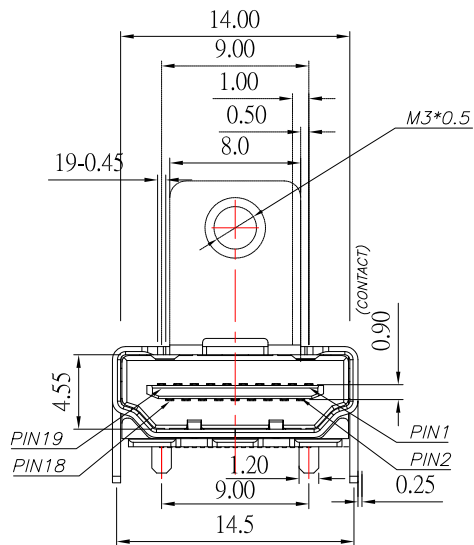

NOTE:

1.MATERIAL:

- 1.1 HOUSING: LCP,UL94V-0 , BLACK
- 1.2 CONTACT: BRASS
- 1.3 SHEEL: BRASS

2.PLATING :

- 2.1 CONTACT: PLATED GOLD IN MATING AREA ;
TIN PLATED ON SOLDER BALLS ;
NICKEL UNDER PLATED OVERALL
- 2.2 SHELL: NICKEL UNDER PLATED SURFACE LAYER

3.MECHANICAL:

- 3.1 INSERTION FORCE: 4.5 Kgf MAX
- 3.2 WITHDRAWAL FORCE: 1.0 ~ 4.0 Kgf

4.ELECTRICAL:

- 4.1 CONTACT RESISTANCE: 30 mΩ Max
- 4.2 INSULATION RESISTANCE: 100MΩ Min
- 4.3 DIELECTRIC WITHSTANDING VOLTAGE: 500V AC / minute
- 4.5 OPERATING TEMPERATURE: -40°C~ 85°C
- 4.6 STORAGE TEMPERATURE: -60°C~ 105°C



TOLERANCE UNLESS OTHERWISE STATED :
 Up to 5 ±0.2
 Above 5 ~ 15 ±0.3
 Above 15 ~ 30 ±0.4
 Above 30 ~ 50 ±0.5
 Angle ±0.3

3RD. ANGEL'S



UNITS MM

DRAWN BY:	DATE	MAT'L	TITLE	CONNECTOR
Jack Lu	10/07/15			
CHECKED BY:	DATE	FINISH	MODLE	HDMI AF 有柱 螺絲孔 H13.38mm
Jacky Chen	10/07/15			
APPROVED BY:	DATE	SCALE	DWG NO.	HDMI-19P-SED2-S297
Tony Kao	10/07/15	1 : 1	PART NO.	HDMI-19P-SED2-S297
		SHEET NO.	1 of 1	

ITEM NO.	DESCRIPTION	DRAWN	DATE